

## 53. Flux Integrals

Let  $S$  be an *orientable* surface within  $R^3$ . In this context, an orientable surface is one with two distinct sides. At any point on an orientable surface, there exists two normal vectors, one pointing in the opposite direction of the other. Most surfaces, especially those defined explicitly by  $z = f(x, y)$ , are orientable. An example of a non-orientable surface is the Moebius Strip. However, these odd surfaces will not play a role in the following discussion.

Let  $\mathbf{F}(x, y, z) = \langle M(x, y, z), N(x, y, z), P(x, y, z) \rangle$  be a vector field in  $R^3$ . Suppose  $\mathbf{F}$  represents the flow of some medium, *e.g.* heat or fluid, through  $R^3$ . The question that arises is: how much flow, as defined by  $\mathbf{F}$ , passes through the surface  $S$  in a given unit of time? We make the reasonable assumption that  $S$  is completely permeable.

At each point on the surface  $S$ , there exists two vectors: one being  $\mathbf{F}$  representing the flow, and a unit normal vector  $\mathbf{n}$ , representing the positive direction. If  $\mathbf{F}$  and  $\mathbf{n}$  point in the same direction (their angle is acute), then their dot product  $\mathbf{F} \cdot \mathbf{n}$  is positive, and at this point we say the flow is positive. Similarly, if  $\mathbf{F}$  and  $\mathbf{n}$  point in opposite directions, their dot product is negative, and we say that there is negative flow at this point. It is possible that  $\mathbf{F} \cdot \mathbf{n}$  is 0, in which case there is no flow through the surface at the point. Since  $\mathbf{F}$  can vary in length, the values given by the dot products can vary in size too.

To gain a rough sense of the total net flow, or **flux**, of a vector field  $\mathbf{F}$  through a surface  $S$ , we sum all such dot products  $\mathbf{F} \cdot \mathbf{n}$ . To sum “all” of the dot products at every point on the surface means to take an integral. The flux of a vector field  $\mathbf{F}$  through a surface  $S$  is given by

$$\iint_R \mathbf{F} \cdot \mathbf{n} \, dS.$$

Here,  $R$  is the region over which the double integral is evaluated. Region  $R$  is the “shadow” surface  $S$  makes on the  $xy$ -plane.

A *closed* surface is one that encloses a finite-volume subregion of  $R^3$  in such a way that there is an “inside” and “outside”. Examples of closed surfaces are cubes, spheres, ellipsoids, and so on.

**Comment:** the notions of “positive” and “negative”, and of “up” and “down”, vary depending on the context. For a typical surface, “positive” direction of flow is usually arbitrarily chosen. For closed surfaces, positive flow is always taken to be from the inside to the outside. That is, normal vectors  $\mathbf{n}$  point “away” from the interior of the subregion.

Setting up a flux integral requires a number of steps. First, a surface  $S$  must be given. If the surface is defined explicitly such as  $z = f(x, y)$ , then its parameterization is

$$\mathbf{r}(x, y) = \langle x, y, f(x, y) \rangle.$$

From this, we can find *unit* normal vectors  $\mathbf{n}$  by using the formulas

$$\mathbf{n} = \frac{\langle f_x(x, y), f_y(x, y), -1 \rangle}{\sqrt{f_x^2(x, y) + f_y^2(x, y) + 1}} \quad \text{or} \quad \mathbf{n} = \frac{\langle -f_x(x, y), -f_y(x, y), 1 \rangle}{\sqrt{f_x^2(x, y) + f_y^2(x, y) + 1}}$$

Recall from the discussion of surface area integrals that

$$dS = \sqrt{f_x^2(x, y) + f_y^2(x, y) + 1} \, dA.$$

Thus, substitutions can be made into the flux integral:

$$\begin{aligned} & \iint_R \mathbf{F} \cdot \mathbf{n} \, dS \\ = & \iint_R \langle M, N, P \rangle \cdot \frac{\langle f_x(x, y), f_y(x, y), -1 \rangle}{\sqrt{f_x^2(x, y) + f_y^2(x, y) + 1}} \sqrt{f_x^2(x, y) + f_y^2(x, y) + 1} \, dA. \end{aligned}$$

Note that the ratio of expressions  $\frac{\langle f_x(x, y), f_y(x, y), -1 \rangle}{\sqrt{f_x^2(x, y) + f_y^2(x, y) + 1}}$  is 1. The flux integral is now

$$\begin{aligned} & \iint_R \langle M, N, P \rangle \cdot \langle f_x(x, y), f_y(x, y), -1 \rangle \, dA, \\ \text{or} & \iint_R \langle M, N, P \rangle \cdot \langle -f_x(x, y), -f_y(x, y), 1 \rangle \, dA. \end{aligned}$$

After taking the dot product, the integrand is a function in variables  $x$  and  $y$ , and normal techniques are used to evaluate the double integrals.

In the examples that follow, we abuse the notation slightly: the vector  $\mathbf{n}$  may not be a unit vector. As long as the normal vector is derived carefully and has the appearance shown above, it will be sufficient.



**Example 53.1:** Find the flux of the vector field  $\mathbf{F}(x, y, z) = \langle 1, 2, 3 \rangle$  through the square  $S$  in the  $xy$ -plane with vertices  $(0,0)$ ,  $(1,0)$ ,  $(0,1)$  and  $(1,1)$ , where positive flow is the positive  $z$  direction. (Since the surface  $S$  lies in the  $xy$ -plane, it is identical to  $R$  in this case).

**Solution:** Since positive flow is in the direction of positive  $z$ , and the surface  $S$  is on the  $xy$ -plane itself, then a unit normal to  $R$  is  $\mathbf{n} = \langle 0, 0, 1 \rangle$ . Thus,  $\mathbf{F} \cdot \mathbf{n} = \langle 1, 2, 3 \rangle \cdot \langle 0, 0, 1 \rangle = 3$ , and the flux is given by

$$\iint_{R(=S)} 3 \, dA = 3 \iint_R dA = 3(\text{Area of } R) = 3(1) = 3.$$

In any unit of time, a total flow of 3 units of mass per unit of time will flow through  $S$ . In this example, the answer could be reasoned without performing the actual integration. Note that from each vector  $\langle 1, 2, 3 \rangle$ , only the  $z$ -component 3 is relevant. That is, in the positive  $z$  direction, the fluid flows at a rate of 3 units of mass per unit of time.

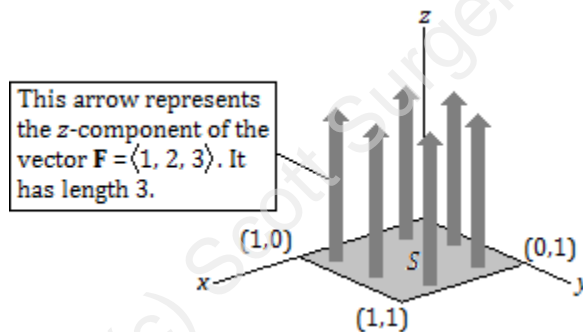

At each point in the square  $S$ , a vector  $\langle 1, 2, 3 \rangle$  is drawn, so it stands to reason that the flux can be viewed as the volume of a box with the square  $S$  as its base, and a height of 3; thus, the volume =  $(1)(1)(3) = 3$ , the flux. If the flow was of water, this box holds the water that flowed through the square  $S$  in one unit of time in the direction of positive  $z$ .

The other components in  $\mathbf{F}$  indicate that the flow travels in a direction that is not orthogonal to  $S$ . But the fact does remain that regardless how far the fluid may travel in the  $x$  or  $y$  directions, after 1 unit of time, 3 units of mass will have flowed in the  $z$ -direction, and that is exactly what we are seeking to determine.

This geometrical phenomenon is known as *Cavalieri's Principle*. You may have "seen" this principle when stacking coins. A perfectly vertical stack will appear as a cylinder and its volume can be easily determined. If the stack is disturbed so that it leans but does not fall over, the vertical height has not changed, nor

has the volume. The  $x$  or  $y$  offset in the lean has no effect on the volume of the stack.



**Example 53.2:** Find the flux of the vector field  $\mathbf{F}(x, y, z) = \langle x, y, -z \rangle$  through the portion of the plane in the first octant with intercepts  $(4,0,0)$ ,  $(0,8,0)$  and  $(0,0,10)$ , where positive flow is defined to be in the positive  $z$  direction.

**Solution:** First, we find an equation for the plane (this is surface  $S$ ). Recall from Example 13.6 that a plane passing through  $(a,0,0)$ ,  $(0,b,0)$  and  $(0,0,c)$  has the general form

$$\frac{x}{a} + \frac{y}{b} + \frac{z}{c} = 1.$$

Thus, the plane here is

$$\frac{x}{4} + \frac{y}{8} + \frac{z}{10} = 1.$$

Clearing fractions, we have  $10x + 5y + 4z = 40$ , or  $z = 10 - \frac{5}{2}x - \frac{5}{4}y$ .

From the plane, There are two normal vectors  $\mathbf{n} = \left\langle -\frac{5}{2}, -\frac{5}{4}, -1 \right\rangle$  or  $\left\langle \frac{5}{2}, \frac{5}{4}, 1 \right\rangle$ . We choose  $\mathbf{n} = \left\langle \frac{5}{2}, \frac{5}{4}, 1 \right\rangle$  since the problem defined positive flow to be in the positive  $z$  direction.

We now find  $\mathbf{F} \cdot \mathbf{n}$ . Note that since  $z = 10 - \frac{5}{2}x - \frac{5}{4}y$ , we write  $\mathbf{F}$  in terms of  $x$  and  $y$ , where  $\mathbf{F}(x, y) = \langle x, y, -z \rangle = \left\langle x, y, -\left(10 - \frac{5}{2}x - \frac{5}{4}y\right) \right\rangle$ . Thus,

$$\begin{aligned} \mathbf{F} \cdot \mathbf{n} &= \left\langle x, y, -10 + \frac{5}{2}x + \frac{5}{4}y \right\rangle \cdot \left\langle \frac{5}{2}, \frac{5}{4}, 1 \right\rangle \\ &= \frac{5}{2}x + \frac{5}{4}y - 10 + \frac{5}{2}x + \frac{5}{4}y \\ &= 5x + \frac{5}{2}y - 10. \end{aligned}$$

This will be the integrand.

The bounds of integration lie in the  $xy$ -plane, the “footprint” of the surface  $S$ ,  $10x + 5y + 4z = 40$  as it is projected onto the  $xy$ -plane (this being  $R$ ):

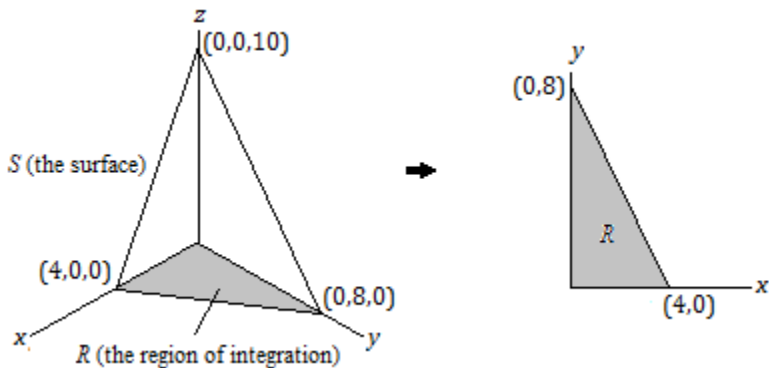

Choosing  $dy dx$  as the order of integration, the bounds on  $y$  are  $0 \leq y \leq 8 - 2x$ , and the bounds on  $x$  are  $0 \leq x \leq 4$ . The flux of  $\mathbf{F}$  through the surface  $S$  is

$$\int_0^4 \int_0^{8-2x} \left( 5x + \frac{5}{2}y - 10 \right) dy dx.$$

Evaluating the inside integral, we have

$$\begin{aligned} \int_0^{8-2x} \left( 5x + \frac{5}{2}y - 10 \right) dy &= \left[ 5xy + \frac{5}{4}y^2 - 10y \right]_0^{8-2x} \\ &= 5x(8 - 2x) + \frac{5}{4}(8 - 2x)^2 - 10(8 - 2x) \\ &= 20x - 5x^2. \quad (\text{After simplification}) \end{aligned}$$

This is integrated with respect to  $x$ :

$$\int_0^4 (20x - 5x^2) dx = \left[ 10x^2 - \frac{5}{3}x^3 \right]_0^4 = 10(4)^2 - \frac{5}{3}(4)^3 = \frac{160}{3}.$$

The flux is positive, and we can say that in one unit of time,  $\frac{160}{3}$  units of material flow through this surface.



It seems plausible that it should not matter in which direction we define to be positive flow. In the next example, we repeat this same problem but in a different “positive” direction.

**Example 53.3:** Find the flux of the vector field  $\mathbf{F}(x, y, z) = \langle x, y, -z \rangle$  through the portion of the plane in the first octant with intercepts  $(4,0,0)$ ,  $(0,8,0)$  and  $(0,0,10)$ , where positive flow is defined to be in the positive  $y$  direction.

**Solution:** From the equation of the plane  $10x + 5y + 4z = 40$ , solve for  $y$ , obtaining  $y = 8 - 2x - \frac{4}{5}z$ , and from this, two normal vectors are identified,  $\langle -2, -1, -\frac{4}{5} \rangle$  or  $\langle 2, 1, \frac{4}{5} \rangle$ . Since the direction is positive  $y$ , choose  $\mathbf{n} = \langle 2, 1, \frac{4}{5} \rangle$ .

The vector field  $\mathbf{F}$  is adjusted too. In place of  $y$ , we substitute  $8 - 2x - \frac{4}{5}z$ :

$$\mathbf{F}(x, z) = \langle x, y, -z \rangle = \left\langle x, 8 - 2x - \frac{4}{5}z, -z \right\rangle.$$

The dot product  $\mathbf{F} \cdot \mathbf{n}$  is now determined:

$$\begin{aligned} \mathbf{F} \cdot \mathbf{n} &= \left\langle x, 8 - 2x - \frac{4}{5}z, -z \right\rangle \cdot \left\langle 2, 1, \frac{4}{5} \right\rangle \\ &= 2x + 8 - 2x - \frac{4}{5}z - \frac{4}{5}z \\ &= 8 - \frac{8}{5}z. \end{aligned}$$

For the bounds of integration, we look at the footprint of the surface  $S$  projected onto the  $xz$  plane:

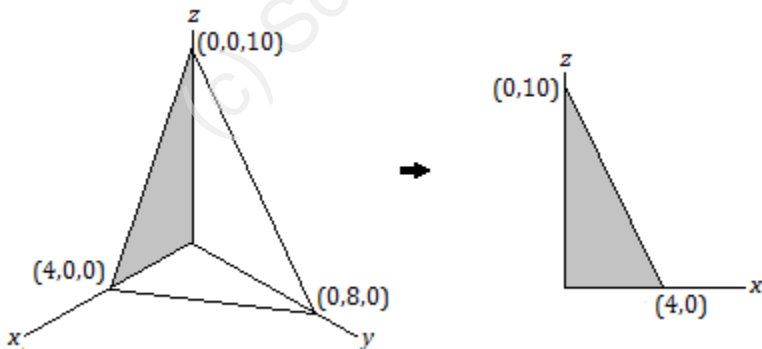

Choosing the  $dz dx$  order of integration, the bounds are  $0 \leq z \leq 10 - \frac{5}{2}x$  and  $0 \leq x \leq 4$ . The flux is given by the double integral

$$\int_0^4 \int_0^{10-(5/2)x} \left( 8 - \frac{8}{5}z \right) dz dx.$$

The inside integral is evaluated:

$$\begin{aligned} \int_0^{10-(5/2)x} \left(8 - \frac{8}{5}z\right) dz &= \left[8z - \frac{4}{5}z^2\right]_0^{10-(5/2)x} \\ &= 8\left(10 - \frac{5}{2}x\right) - \frac{4}{5}\left(10 - \frac{5}{2}x\right)^2 \\ &= 20x - 5x^2. \quad (\text{after simplification}) \end{aligned}$$

The outside integral is evaluated:

$$\int_0^4 (20x - 5x^2) dx = \left[10x^2 - \frac{5}{3}x^3\right]_0^4 = 10(4)^2 - \frac{5}{3}(4)^3 = \frac{160}{3}.$$

And we arrive at the same result. This should not be surprising. If you are feeling energetic, repeat the problem where the positive direction of flow is the positive  $x$  direction.



**Example 53.4:** Find the flux of the vector field  $\mathbf{F}(x, y, z) = \langle z, 2x, y \rangle$  through the portion of the paraboloid  $z = 9 - x^2 - y^2$  above the  $xy$ -plane and confined to the first octant, where positive flow is in the positive  $z$ -direction.

**Solution:** Following the forms  $\langle f_x, f_y, -1 \rangle$  or  $\langle -f_x, -f_y, 1 \rangle$ , the normal vectors to the surface are

$$\langle -2x, -2y, -1 \rangle \quad \text{or} \quad \langle 2x, 2y, 1 \rangle.$$

We use  $\mathbf{n} = \langle 2x, 2y, 1 \rangle$  since it agrees with the positive  $z$  direction. Next, vector field  $\mathbf{F}$  is written in terms of  $x$  and  $y$  only:

$$\mathbf{F}(x, y) = \langle 9 - x^2 - y^2, 2x, y \rangle.$$

Thus, the dot product  $\mathbf{F} \cdot \mathbf{n}$  is:

$$\begin{aligned} \mathbf{F} \cdot \mathbf{n} &= (9 - x^2 - y^2)(2x) + (2x)(2y) + (y)(1) \\ &= (9 - x^2 - y^2)2x + 4xy + y. \end{aligned}$$

The region of integration  $R$  is a filled-in quarter-circle on the  $xy$ -plane with radius 3, with its center at the origin. We use polar coordinates. Using the substitutions  $x = r \cos \theta$  and  $y = r \sin \theta$ , the bounds of integration become  $0 \leq r \leq 3$  and  $0 \leq \theta \leq \frac{\pi}{2}$ . Recall also that the area element  $dA = r dr d\theta$ .

The expression  $(9 - x^2 - y^2)2x + 4xy + y$  is also written in terms of  $r$  and  $\theta$ :

$$(9 - (r \cos \theta)^2 - (r \sin \theta)^2)2(r \cos \theta) + 4(r \cos \theta)(r \sin \theta) + (r \sin \theta).$$

Note that  $(9 - (r \cos \theta)^2 - (r \sin \theta)^2) = 9 - r^2$ . Thus, we have

$$(9 - r^2)2(r \cos \theta) + 4(r \cos \theta)(r \sin \theta) + (r \sin \theta).$$

This is further simplified:

$$18r \cos \theta - 2r^3 \cos \theta + 4r^2 \cos \theta \sin \theta + r \sin \theta.$$

Finally, the flux integral is

$$\int_0^{\pi/2} \int_0^3 (18r \cos \theta - 2r^3 \cos \theta + 4r^2 \cos \theta \sin \theta + r \sin \theta) r \, dr \, d\theta.$$

Distribute the  $r$ :

$$\int_0^{\pi/2} \int_0^3 (18r^2 \cos \theta - 2r^4 \cos \theta + 4r^3 \cos \theta \sin \theta + r^2 \sin \theta) \, dr \, d\theta.$$

The inside integral is evaluated:

$$\begin{aligned} & \int_0^3 (18r^2 \cos \theta - 2r^4 \cos \theta + 4r^3 \cos \theta \sin \theta + r^2 \sin \theta) \, dr \\ &= \left[ 6r^3 \cos \theta - \frac{2}{5}r^5 \cos \theta + r^4 \cos \theta \sin \theta + \frac{1}{3}r^3 \sin \theta \right]_0^3 \\ &= 162 \cos \theta - \frac{486}{5} \cos \theta + 81 \cos \theta \sin \theta + 9 \sin \theta \\ &= \frac{324}{5} \cos \theta + 81 \cos \theta \sin \theta + 9 \sin \theta. \quad \left\{ 162 - \frac{486}{5} = \frac{324}{5} \right\} \end{aligned}$$

This is integrated with respect to  $\theta$ :

$$\begin{aligned} & \int_0^{\pi/2} \left( \frac{324}{5} \cos \theta + 81 \cos \theta \sin \theta + 9 \sin \theta \right) \, d\theta \\ &= \left[ \frac{324}{5} \sin \theta + \frac{81}{2} \sin^2 \theta - 9 \cos \theta \right]_0^{\pi/2} \end{aligned}$$



Note that  $\sin\left(\frac{\pi}{2}\right) = 1$ ,  $\sin(0) = 0$ ,  $\cos\left(\frac{\pi}{2}\right) = 0$  and  $\cos(0) = 1$ :

$$\begin{aligned} & \left[ \frac{324}{5} \sin \theta + \frac{81}{2} \sin^2 \theta - 9 \cos \theta \right]_0^{\pi/2} \\ &= \left( \frac{324}{5} (1) + \frac{81}{2} (1) - 9(0) \right) - \left( \frac{324}{5} (0) + \frac{81}{2} (0) - 9(1) \right) \\ &= \frac{1143}{10}. \end{aligned}$$

There is a lot of positive flow through this surface, as indicated by the result. As much work as this seemed to be, it took advantage of many of the nicer aspects of polar integration.



The following three examples discuss flux through a closed surface. Thus, we must choose  $\mathbf{n}$  to point away from the interior of the closed surface.

**Example 53.5:** Find the net flux of the vector field  $\mathbf{F}(x, y, z) = \langle x, y, 1 \rangle$  through the closed surface of the hemisphere  $x^2 + y^2 + z^2 = 4$  above the  $xy$ -plane, whose base is on the  $xy$ -plane.

**Solution:** For the hemisphere, the normal vectors will point in the direction of positive  $z$ , away from the interior. Isolate  $z$  in the equation  $x^2 + y^2 + z^2 = 4$ :

$$z = f(x, y) = \sqrt{4 - x^2 - y^2}.$$

Using the form  $\mathbf{n} = \langle -f_x, -f_y, 1 \rangle$ , we have

$$\mathbf{n} = \left\langle \frac{x}{\sqrt{4 - x^2 - y^2}}, \frac{y}{\sqrt{4 - x^2 - y^2}}, 1 \right\rangle.$$

There is no  $z$ -variable in  $\mathbf{F}$ , so there is no need to make any substitutions. Vector field  $\mathbf{F}$  is already in terms of  $x$  and  $y$ . The dot product  $\mathbf{F} \cdot \mathbf{n}$  is

$$\begin{aligned} \mathbf{F} \cdot \mathbf{n} &= \langle x, y, 1 \rangle \cdot \left\langle \frac{x}{\sqrt{4 - x^2 - y^2}}, \frac{y}{\sqrt{4 - x^2 - y^2}}, 1 \right\rangle \\ &= \frac{x^2}{\sqrt{4 - x^2 - y^2}} + \frac{y^2}{\sqrt{4 - x^2 - y^2}} + 1 \\ &= \frac{x^2 + y^2}{\sqrt{4 - x^2 - y^2}} + 1. \end{aligned}$$

This is the integrand of the flux integral. We will use polar coordinates to evaluate. The region of integration in the  $xy$ -plane is a circle of radius 2, centered at the origin. Using  $x = r \cos \theta$  and  $y = r \sin \theta$ , with bounds  $0 \leq r \leq 2$  and  $0 \leq \theta \leq 2\pi$ , the integrand becomes

$$\frac{r^2}{\sqrt{4-r^2}} + 1,$$

and the flux through the hemisphere is

$$\int_0^{2\pi} \int_0^2 \left( \frac{r^2}{\sqrt{4-r^2}} + 1 \right) r \, dr \, d\theta.$$

The inside integral is evaluated. A table of integrals is used to determine the antiderivative:

$$\begin{aligned} \int_0^2 \left( \frac{r^2}{\sqrt{4-r^2}} + 1 \right) r \, dr &= \int_0^2 \left( \frac{r^3}{\sqrt{4-r^2}} + r \right) dr \\ &= \left[ -\frac{1}{3}(r^2+8)\sqrt{4-r^2} + \frac{1}{2}r^2 \right]_0^2 \\ &= 2 - \left( -\frac{1}{3}(8)(2) \right) = \frac{22}{3}. \end{aligned}$$

Then the outside integral is evaluated:

$$\int_0^{2\pi} \left( \frac{22}{3} \right) d\theta = \frac{22}{3} \int_0^{2\pi} d\theta = \frac{22}{3} (2\pi) = \frac{44\pi}{3}.$$

Now, we evaluate the flux through the base itself, the circle of radius 2 centered at the origin. Since this surface lies in the  $xy$ -plane, we will use  $\mathbf{n} = \langle 0, 0, -1 \rangle$  because the positive orientation of flow is *away* from the interior (note that  $\langle 0, 0, 1 \rangle$  would point inside the object). The dot product  $\mathbf{F} \cdot \mathbf{n}$  is

$$\mathbf{F} \cdot \mathbf{n} = \langle x, y, 1 \rangle \cdot \langle 0, 0, -1 \rangle = -1.$$

Thus, the flux through the circle of radius 2 is

$$\iint_R (-1) \, dA = - \iint_R dA = -4\pi.$$

Note that  $\iint_R dA$  represents the area of the circle of radius 2, which is  $4\pi$ . Adding the two flux values for the two surfaces that compose the closed surface, the total net flux through this hemisphere and its base is  $\frac{44\pi}{3} + (-4\pi) = \frac{32\pi}{3}$ .

**Example 53.6:** Find the net flux of  $\mathbf{F}(x, y, z) = \langle 2x, y, 4z \rangle$  through a cube in the first octant with vertices  $(0,0,0)$ ,  $(1,0,0)$ ,  $(1,1,0)$ ,  $(0,1,0)$ ,  $(0,0,1)$ ,  $(1,0,1)$ ,  $(1,1,1)$  and  $(0,1,1)$ .

**Solution:** To find the net flux, we need to find the flux through each of the box's six surfaces, then sum these values. The box is enclosed by the planes  $x = 0$ ,  $y = 0$ ,  $z = 0$ ,  $x = 1$ ,  $y = 1$  and  $z = 1$ .

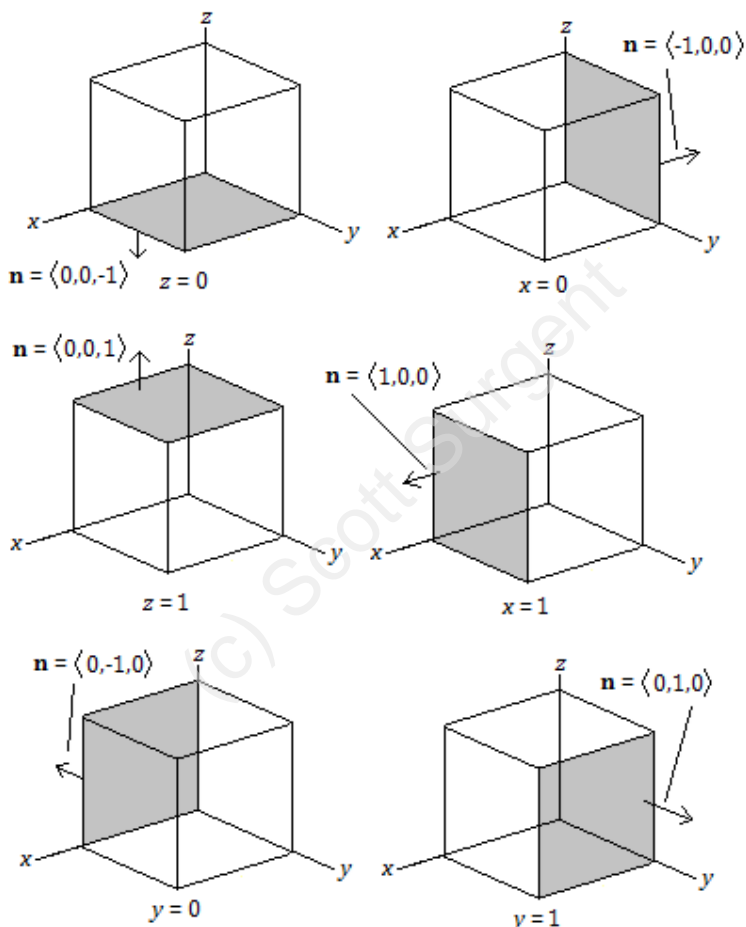

The six normal vectors  $\mathbf{n}$  for each of the six surfaces of the box.  
Note that each  $\mathbf{n}$  points away from the interior of the cube.

For the surface  $z = 0$ , the normal vector points in the direction of negative  $z$ , so  $\mathbf{n} = \langle 0, 0, -1 \rangle$ . The equation  $z = 0$  is substituted into  $\mathbf{F}$ , so that  $\mathbf{F}(x, y, 0) = \langle 2x, y, 0 \rangle$ . Therefore,  $\mathbf{F} \cdot \mathbf{n} = \langle 2x, y, 0 \rangle \cdot \langle 0, 0, -1 \rangle = 0$ . The flux is zero—there is no flow generated by the vector field  $\mathbf{F}$  through the surface  $z = 0$ .

For the surface  $x = 0$ , the normal vector points in the direction of negative  $x$ , so  $\mathbf{n} = \langle -1, 0, 0 \rangle$ . The equation  $x = 0$  is substituted into  $\mathbf{F}$ , so that  $\mathbf{F}(0, y, z) = \langle 0, y, 4z \rangle$ . Therefore,  $\mathbf{F} \cdot \mathbf{n} = \langle 0, y, 4z \rangle \cdot \langle -1, 0, 0 \rangle = 0$ . The flux is zero—there is no flow generated by the vector field  $\mathbf{F}$  through the surface  $x = 0$ .

For the surface  $z = 1$ , the normal vector points in the direction of positive  $z$ , so  $\mathbf{n} = \langle 0, 0, 1 \rangle$ . The equation  $z = 1$  is substituted into  $\mathbf{F}$ , so that  $\mathbf{F}(x, y, 1) = \langle 2x, y, 4(1) \rangle$ . Therefore,  $\mathbf{F} \cdot \mathbf{n} = \langle 2x, y, 4 \rangle \cdot \langle 0, 0, 1 \rangle = 4$ . The flux through  $z = 1$  is  $\iint_R 4 \, dA = 4 \iint_R dA = 4(1) = 4$ , where  $\iint_R dA$  is the area of the surface, which is a square with side lengths 1.

For the surface  $x = 1$ , the normal vector points in the direction of positive  $x$ , so  $\mathbf{n} = \langle 1, 0, 0 \rangle$ . The equation  $x = 1$  is substituted into  $\mathbf{F}$ , so that  $\mathbf{F}(1, y, z) = \langle 2(1), y, 4z \rangle$ . Therefore,  $\mathbf{F} \cdot \mathbf{n} = \langle 2, y, 4z \rangle \cdot \langle 1, 0, 0 \rangle = 2$ . The flux through  $x = 1$  is given by  $\iint_R 2 \, dA = 2 \iint_R dA = 2(1) = 2$ .

For the surface  $y = 0$ , the normal vector points in the direction of negative  $y$ , so  $\mathbf{n} = \langle 0, -1, 0 \rangle$ . The equation  $y = 0$  is substituted into  $\mathbf{F}$ , so that  $\mathbf{F}(x, 0, z) = \langle 2x, 0, 4z \rangle$ . Therefore,  $\mathbf{F} \cdot \mathbf{n} = \langle 2x, 0, 4z \rangle \cdot \langle 0, -1, 0 \rangle = 0$ . The flux is zero—there is no flow generated by the vector field  $\mathbf{F}$  through the surface  $y = 0$ .

For the surface  $y = 1$ , the normal vector points in the direction of positive  $y$ , so  $\mathbf{n} = \langle 0, 1, 0 \rangle$ . The equation  $y = 1$  is substituted into  $\mathbf{F}$ , so that  $\mathbf{F}(x, 1, z) = \langle 2x, 1, 4z \rangle$ . Therefore,  $\mathbf{F} \cdot \mathbf{n} = \langle 2x, 1, 4z \rangle \cdot \langle 0, 1, 0 \rangle = 1$ . The flux through  $y = 1$  is given by  $\iint_R 1 \, dA = 1 \iint_R dA = 1$ .

Thus, the total net flux is the sum of these values:  $0 + 0 + 0 + 4 + 2 + 1 = 7$  units of mass per unit of time.



See an error? Have a suggestion?  
Please see [www.surgent.net/vcbook](http://www.surgent.net/vcbook)

**Example 53.7:** Find the net flux of  $\mathbf{F}(x, y, z) = \langle xy, -y, z \rangle$  through the closed surface composed of the cylinder  $x^2 + y^2 = 4$  and the planes,  $y = 0$ ,  $z = 1$  and  $z = 6$ .

**Solution:** The object is shown below:

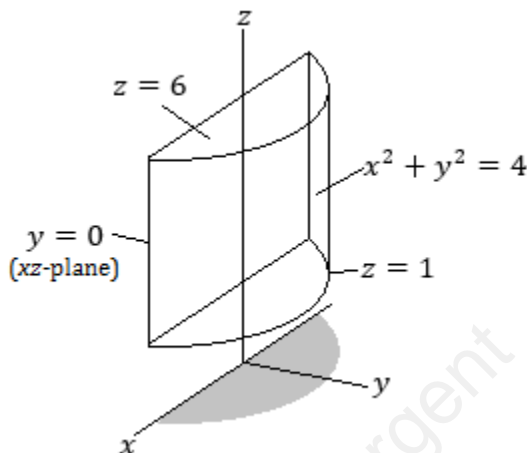

The flux through the planes can be found quickly.

For  $z = 1$ , we use  $\mathbf{n} = \langle 0, 0, -1 \rangle$  since the direction of positive flow will be away from the interior bounded by the surface. Also, since  $z = 1$ , we have  $\mathbf{F}(x, y, 1) = \langle xy, -y, 1 \rangle$ . Thus, we have  $\mathbf{F} \cdot \mathbf{n} = \langle xy, -y, 1 \rangle \cdot \langle 0, 0, -1 \rangle = -1$ . The region of integration  $R$  is a half-circle in the  $xy$ -plane of radius 2, its center at the origin (in gray, above). The flux through this plane is

$$\iint_R (-1) dA = - \iint_R dA = - \left( \begin{array}{l} \text{Area inside half of a} \\ \text{circle of radius 2} \end{array} \right) = -\frac{1}{2}\pi(2)^2 = -2\pi.$$

For  $z = 6$ , we use  $\mathbf{n} = \langle 0, 0, 1 \rangle$ , which points upward, away from the interior bounded by the surface. Also, since  $z = 6$ , we have  $\mathbf{F}(x, y, 6) = \langle xy, -y, 6 \rangle$ . Thus, we have  $\mathbf{F} \cdot \mathbf{n} = \langle xy, -y, 6 \rangle \cdot \langle 0, 0, 1 \rangle = 6$ . The region of integration  $R$  is the same as above. The flux through this plane is

$$\iint_R (6) dA = 6 \iint_R dA = 6 \left( \frac{1}{2}\pi(2)^2 \right) = 12\pi.$$

For  $y = 0$ , we use  $\mathbf{n} = \langle 0, -1, 0 \rangle$ , keeping in mind we want the normal vector to point outward from the interior bounded by the surface. We have  $\mathbf{F}(x, 0, z) = \langle 0, 0, z \rangle$ , so that  $\mathbf{F} \cdot \mathbf{n} = 0$ . Thus, the flux through this plane is 0.

For the cylinder  $x^2 + y^2 = 4$ , we parameterize it in cylindrical coordinates using two variables:

$$\mathbf{r}(u, v) = \langle 2 \cos u, 2 \sin u, v \rangle, \quad \text{where } 0 \leq u \leq \pi \quad \text{and} \quad 1 \leq v \leq 6.$$

To find a normal vector  $\mathbf{n}$  to this surface, find  $\mathbf{r}_u$  and  $\mathbf{r}_v$  and then find  $\mathbf{r}_u \times \mathbf{r}_v$ :

$$\mathbf{r}_u = \langle -2 \sin u, 2 \cos u, 0 \rangle \quad \text{and} \quad \mathbf{r}_v = \langle 0, 0, 1 \rangle;$$

$$\text{thus, } \mathbf{n} = \mathbf{r}_u \times \mathbf{r}_v = \langle 2 \cos u, 2 \sin u, 0 \rangle.$$

Vector field  $\mathbf{F}$  is rewritten in terms of  $u$  and  $v$ , where  $x = 2 \cos u$  and  $y = 2 \sin u$ :

$$\mathbf{F}(u, v) = \langle (2 \cos u)(2 \sin u), -(2 \sin u), v \rangle = \langle 4 \cos u \sin u, -2 \sin u, v \rangle.$$

The dot product is

$$\begin{aligned} \mathbf{F} \cdot \mathbf{n} &= \langle 4 \cos u \sin u, -2 \sin u, v \rangle \cdot \langle 2 \cos u, 2 \sin u, 0 \rangle \\ &= 8 \cos^2 u \sin u - 4 \sin^2 u. \end{aligned}$$

The flux through the cylinder alone is

$$\int_1^6 \int_0^\pi (8 \cos^2 u \sin u - 4 \sin^2 u) \, du \, dv.$$

We use the identity  $\sin^2 u = \frac{1}{2} - \frac{1}{2} \cos(2u)$ , then simplify:

$$\begin{aligned} \int_1^6 \int_0^\pi \left( 8 \cos^2 u \sin u - 4 \left( \frac{1}{2} - \frac{1}{2} \cos(2u) \right) \right) \, du \, dv \\ = \int_1^6 \int_0^{2\pi} (8 \cos^2 u \sin u - 2 + 2 \cos(2u)) \, du \, dv. \end{aligned}$$

The inside integral is evaluated:

$$\begin{aligned} \int_0^\pi (8 \cos^2 u \sin u - 2 + 2 \cos(2u)) \, du &= \left[ -\frac{8}{3} \cos^3 u - 2u + \sin(2u) \right]_0^{2\pi} \\ &= \frac{16}{3} - 2\pi. \end{aligned}$$

The outside integral is evaluated:

$$\int_1^6 \left( \frac{16}{3} - 2\pi \right) \, dv = \left( \frac{16}{3} - 2\pi \right) \int_1^6 \, dv = \left( \frac{16}{3} - 2\pi \right) (5) = \frac{80}{3} - 10\pi.$$

The net flux through the closed surface is  $-2\pi + 12\pi + \frac{80}{3} - 10\pi = \frac{80}{3}$ .



Determining the flux through a closed surfaces can be tedious since we usually must determine the flux through all surfaces of the object. However, there is a faster way to find the flux through such surfaces, using the divergence operator. This is called the *divergence theorem*.

## 54. The Divergence Theorem

Let  $S$  be a closed surface that encloses a subregion in  $R^3$  in such a way that the surface creates a distinct inside and outside. Let  $\mathbf{F}(x, y, z)$  be a vector field in  $R^3$ . To find the total flow of mass through  $S$ , we can use the **divergence theorem**:

$$\iint_R \mathbf{F} \cdot \mathbf{n} \, dS = \iiint_S \operatorname{div} \mathbf{F} \, dV.$$

We are slightly abusing the notation here. The subscript  $S$  in the triple integral is the surface, but the integral itself is evaluated over the region enclosed by the surface.



**Example 54.1:** Find the net flux of the vector field  $\mathbf{F}(x, y, z) = \langle x, y, 1 \rangle$  through the closed surface of the hemisphere  $x^2 + y^2 + z^2 = 4$  above the  $xy$ -plane, whose base is on the  $xy$ -plane. (This is a repeat of Example 53.5)

**Solution:** We use the divergence theorem. The divergence of  $\mathbf{F}$  is

$$\begin{aligned} \operatorname{div} \mathbf{F} &= \nabla \cdot \mathbf{F} = \langle \partial_x, \partial_y, \partial_z \rangle \cdot \langle x, y, 1 \rangle \\ &= 1 + 1 + 0 \\ &= 2. \end{aligned}$$

The flux is then given by

$$\begin{aligned} \iiint_S \operatorname{div} \mathbf{F} \, dV &= \iiint_S 2 \, dV \\ &= 2 \iiint_S dV \\ &= 2 \left( \begin{array}{l} \text{volume inside a hemisphere} \\ \text{with radius 2} \end{array} \right) \end{aligned}$$

$$= 2 \left( \frac{1}{2} \left( \frac{4}{3} \pi (2)^3 \right) \right) = \frac{32\pi}{3}.$$

Here,  $\iiint_S dV$  is the volume of the subregion in  $R^3$  enclosed by  $S$ .



If  $\text{div } \mathbf{F}$  is a constant, then geometry may be used to determine  $\iiint_S dV$ .

**Example 54.2:** Find the net flux of  $\mathbf{F}(x, y, z) = \langle 2x, y, 4z \rangle$  through a cube in the first octant with vertices  $(0,0,0)$ ,  $(1,0,0)$ ,  $(1,1,0)$ ,  $(0,1,0)$ ,  $(0,0,1)$ ,  $(1,0,1)$ ,  $(1,1,1)$  and  $(0,1,1)$ . (This is a repeat of Example 53.6)

**Solution:** Find the divergence of  $\mathbf{F}$ :

$$\begin{aligned} \text{div } \mathbf{F} &= \nabla \cdot \mathbf{F} = \langle \partial_x, \partial_y, \partial_z \rangle \cdot \langle 2x, y, 4z \rangle \\ &= 2 + 1 + 4 \\ &= 7. \end{aligned}$$

Thus, the flux through the solid cube with side lengths 1 is

$$\begin{aligned} \iiint_S \text{div } \mathbf{F} dV &= \iiint_S 7 dV \\ &= 7 \iiint_S dV \\ &= 7(1)^3 \\ &= 7. \end{aligned}$$



**Example 54.3:** Find the net flux of  $\mathbf{F}(x, y, z) = \langle xy, -y, z \rangle$  through the closed surface composed of the cylinder  $x^2 + y^2 = 4$  and the planes,  $y = 0$ ,  $z = 1$  and  $z = 6$ . (This is a repeat of Example 53.7)

**Solution:** The divergence of  $\mathbf{F}$  is  $\nabla \cdot \mathbf{F} = y$ , and by the divergence theorem, the net flux through this closed surface is (using polar coordinates with  $y = r \sin \theta$ ):

$$\iiint_S y dV = \int_1^6 \int_0^\pi \int_0^2 (r \sin \theta) r dr d\theta dz = \int_1^6 \int_0^\pi \int_0^2 r^2 \sin \theta dr d\theta dz.$$

Since the bounds are constants and the integrand is held by multiplication, we evaluate this triple integral as a product of three single-variable integrals:



$$\left(\int_1^6 dz\right)\left(\int_0^\pi \sin \theta \, d\theta\right)\left(\int_0^2 r^2 \, dr\right) = (5)(2)\left(\frac{8}{3}\right) = \frac{80}{3}.$$



Note the efficiency of the divergence theorem on closed surfaces by comparing the previous three examples with the earlier examples.

**Example 54.4:** Let  $\mathbf{F}(x, y, z) = \langle 5x + e^y, \sin(x^2) + 2y, \tan^{-1}(xy) - z \rangle$ . Find the flux of  $\mathbf{F}$  through the closed surface that is a right circular cone, including its base, with base radius of 3 on the  $yz$ -plane, and apex at  $(4, 0, 0)$ .

**Solution:** The divergence of  $\mathbf{F}$  is  $\nabla \cdot \mathbf{F} = 5 + 2 - 1 = 6$  (you verify). The flux is given by

$$\iiint_S 6 \, dV = 6(\text{volume inside the cone}).$$

The volume of a right circular cone is  $\frac{1}{3}\pi r^2 h$ . Here,  $r = 3$  and  $h = 4$  since the apex is 4 units from the  $yz$ -plane. Thus, the flux is  $6\left(\frac{1}{3}\pi(3)^2(4)\right) = 72\pi$ .



**Example 54.5:** Find the net flux of  $\mathbf{F}(x, y, z) = \langle 3, 5, 9 \rangle$  through a sphere of radius 1, centered at the origin.

**Solution:** The divergence of  $\mathbf{F}$  is  $\nabla \cdot \mathbf{F} = 0 + 0 + 0 = 0$ . Therefore, there is zero net flux through the sphere, or any other closed surface for that matter.

This does not mean that there is zero flux on all faces or sides of the closed surface. It means that equal amounts of matter are entering and leaving through the closed surface per unit time. For example, a four-sided object may have flux figures of 3, 5, 2 and  $-10$  among its four sides. Its net flux is 0.

All constant vector fields  $\mathbf{F}$  have  $\text{div } \mathbf{F} = 0$ . Constant vector fields are incompressible. However, not all incompressible vector fields (those with  $\text{div } \mathbf{F} = 0$ ) are constant vector fields. Consider the case when  $\mathbf{F}(x, y, z) = \langle z, x, y \rangle$ .

**Example 54.6:** Find the flux of  $\mathbf{F}(x, y, z) = \left\langle \frac{1}{3}x^3, \frac{1}{3}y^3, 2 \right\rangle$  through the portion of the surface (paraboloid)  $z = 1 - x^2 - y^2$  that lies above the  $xy$ -plane, where positive flow is the direction of positive  $z$ .

**Solution:** Note that the problem asks only for the flux through this specific surface, which is not a closed surface. To use the divergence theorem, we need a closed surface. So we “close off” this surface by including its base, a circle of radius 1 on the  $xy$ -plane. We can then determine the net flux through this closed surface using the divergence theorem. We also determine the flux through the base. The difference will be the flux through the paraboloid.

The flux through the base is found first. Because this surface is now part of a closed surface, its direction of positive flow will be “away” from the inside of the closed surface—in this case, in the direction of negative  $z$ . So we use  $\mathbf{n} = \langle 0, 0, -1 \rangle$ . Meanwhile, the  $xy$ -plane means that  $z = 0$ , so that  $\mathbf{F}(x, y, 0) = \left\langle \frac{1}{3}x^3, \frac{1}{3}y^3, 2 \right\rangle$ . The dot product is

$$\mathbf{F} \cdot \mathbf{n} = \left\langle \frac{1}{3}x^3, \frac{1}{3}y^3, 2 \right\rangle \cdot \langle 0, 0, -1 \rangle = -2.$$

The flux through the circle of radius 1 on the  $xy$ -plane is

$$\iint_R (-2) dA = -2 \iint_R dA = -2 (\text{area inside a circle of radius 1}) = -2\pi.$$

Now, the divergence theorem is used on the entire closed surface—the paraboloid along with its base. We have  $\text{div } \mathbf{F} = x^2 + y^2$ , and since we will integrate with respect to  $x$  and  $y$ , where the region of integration is a circle of radius 1, we use polar coordinates and common trigonometric identities:

$$\begin{aligned} \int_0^{2\pi} \int_0^1 ((r \cos \theta)^2 + (r \sin \theta)^2) r dr d\theta &= \int_0^{2\pi} \int_0^1 r^2 r dr d\theta \\ &= \int_0^{2\pi} \int_0^1 r^3 dr d\theta. \end{aligned}$$

The inside integral is

$$\int_0^1 r^3 dr = \left[ \frac{1}{4} r^4 \right]_0^1 = \frac{1}{4}.$$

The outer integral is

$$\int_0^{2\pi} \frac{1}{4} d\theta = \frac{1}{4} \int_0^{2\pi} d\theta = \frac{1}{4} (2\pi) = \frac{1}{2} \pi.$$

Thus, we have “Flux through the base + Flux through the paraboloid = Flux through the entire object”:

$$-2\pi + Q = \frac{1}{2}\pi$$

The flux through the paraboloid alone is  $Q = \frac{5}{2}\pi$ .

You can decide if it's faster to determine the flux of the surface directly, or to try this method.

(c) Scott Sargent